

CC020-A

Main Document

Essex Net Zero
Specifications
Guide
(Residential)

September 2025



Issue	Description	Date (DD.MM.YY)	Prepared By	Signed Off
01	Draft Issue	05.04.2024	ZK	CM
02	Comments addressed	17.05.2024	ZK	YM
03	Minor tweaks	04.07.2024	ZK	YM
04	Minor amendments to policy cross references	22.09.2025	ZK	YM
05	Minor amendments to policy page links	10.10.2025	ZK	YM

Project Office

Introba Consulting Ltd
 150 Holborn
 London
 EC1N 2NS
 +44(0) 20 3697 9300

Project Contact:

Zeina Krayim
 zeina.krayim@introba.com

Disclaimer

The information contained in this report may contain confidential or legally privileged information. It has been prepared for the sole benefit of our client and can only be relied upon only for its intended use. Introba Consulting Ltd do not confer or purport to confer on any third party, any benefit or any right to rely upon or use any part of this report. Copyright of this document remains with. Introba Consulting Ltd
 ©Introba 2023
 www.introba.com

V5.0

| 1.0 Executive Summary

Residential Buildings - Net Zero Specifications – Executive Summary

The Essex Climate Action Commission have commissioned Introba, Levitt Bernstein, Etude and Currie & Brown to develop the Essex Net Zero Specifications Guide for six different residential typologies. The Net Zero Specifications within this guide outline packaged solutions that meet [Policy GE1: Operational Energy and Carbon \(Net Zero\) in Homes and Buildings](#) (as set out in the [‘Operational Energy & Carbon \(Net Zero\) – Planning Policy Statement \(2025\)’](#) requirements, which are listed below. For each typology, a 2-page guide has been developed which covers fabric and system options in addition to MVHR best practice design guidance. The document also includes high level guidance on design considerations and thermal bridging.



For each typology fabric specifications and heating system options have been presented. It must be noted that the specifications listed do not guarantee that the space heating demand and energy use intensity limits are met, as there are other factors that influence these, such as form factor, orientation and glazing ratios. However, they do present an indication on what is required to achieve the policy. It should be noted that the fabric U-values are presented as a range, and the system options have various levels of efficiency, careful consideration should be taken when combining the fabric and system options. It is not recommended that the worst performing fabric is combined with the least efficient system, as meeting the space heating demand and energy use intensity limits may not be possible.

This report focusses on the operational energy of residential buildings, however it is important that the life cycle embodied carbon emissions are also considered, to make sure that each area is optimised and clearly demonstrated in design and construction. For embodied carbon policy requirements and guidance, please refer to the [“Essex Embodied Carbon Policy Study”](#) and the [“Embodied Carbon and Circular Economy Planning Policy Statement \(2025\)”](#).

In addition to this report, the “Essex Net Zero Specifications Guide – Supporting Document” has been developed alongside to bring background information on topics not covered within this report. It provides high level advice on the requirements regardless of meeting Net Zero, aesthetics of Net Zero and achieving Net Zero at low cost. The document also identifies whether there are material and supply chain gaps in Essex, in addition to providing an elemental cost breakdown of the proposed operational policy’s net zero specifications and the Part L 2021 baseline that were used in the “Essex Net Zero Policy – Technical Evidence Base” report issued in 2025.

The following six residential typologies are covered in this Net Zero Specifications Guide.

1. Semi-detached house

(pages 5-6)

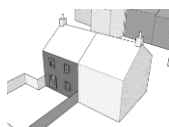

4. Low-rise block of flats

(pages 11-12)



2. Terrace block

(pages 7-8)

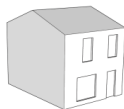

5. Mid-rise block of flats

(pages 13-14)



3. Bungalow

(pages 9-10)

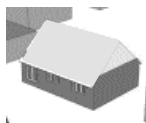

6. High-rise block of flats

(pages 15-16)



Legend for Net Zero specification pages

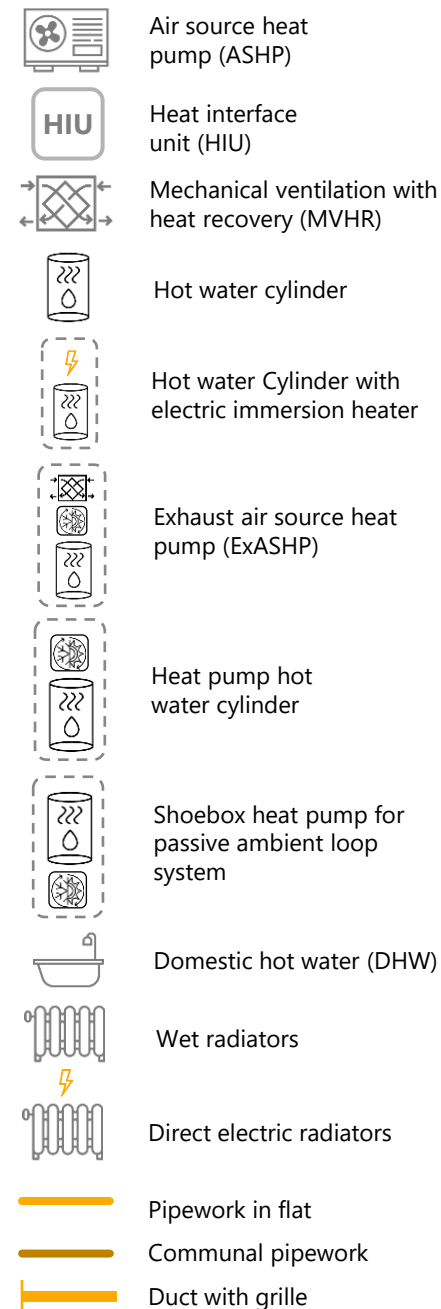

2.0 General Design Guidance

- Getting the design right first
- Thermal bridging

General guidance – getting the design right first

A building's energy demand can be significantly impacted by its **form factor, orientation and glazing ratios**. Although fabric and building services specifications are fundamental in determining a building's energy demand, it is very important that the building is designed right first.

Form factor

Form factor is defined as the ratio of the exposed surface areas of the building fabric to the internal floor area. The lower the form factor, the lower the heat losses thus the lower the energy demand, thus the more efficient the building. Form factor is measured by dividing the exposed external surface area by the building's gross internal floor area. The following gives high-level guidance on how to reduce a building's form factor:

1. Minimise surface area by joining houses together under one thermal envelope to reduce the exposed heat loss areas.

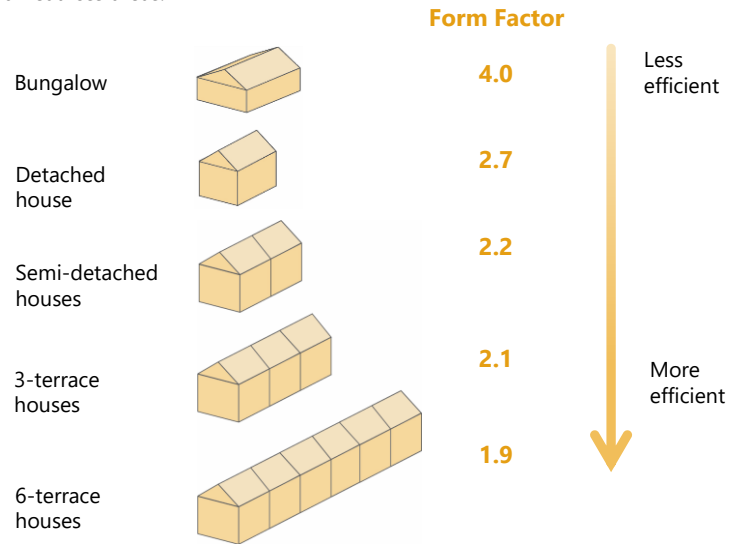

2. Simplify form by reducing overly articulated shapes such as stepped roofs, stepped facades, overhangs, roof terraces and inset balconies. By simplifying the building form, the exposed surface area is reduced, complicated architectural details are mitigated, and cost is brought down.

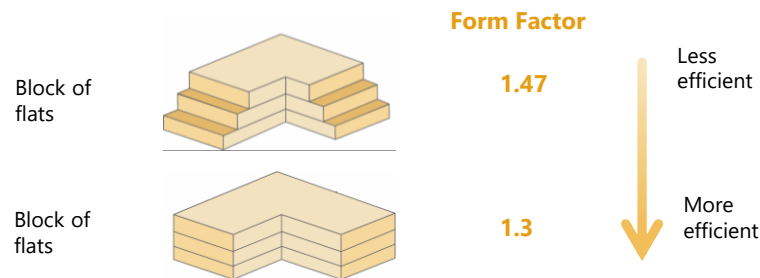

Orientation

It's important that orientation is considered at an early stage of the design to reduce its space heating demand by properly capturing useful solar gain opportunities. This can be achieved by orientating the largest elevation to face South (+/- 30°), in addition to arranging the rooms with the highest occupied hours along the South façade. However, it is important that the amount of glazing and solar shading is considered alongside orientation to prevent the risk of overheating in the Summer. Refer to the ['Essex Solar Design Guide'](#) for more detailed advice on good solar design.

The diagram below shows the impact of different orientations on the space heating demand of the same building. This shows that as the building's main façade is changed from South facing to north facing, its space heating demand is almost doubled.

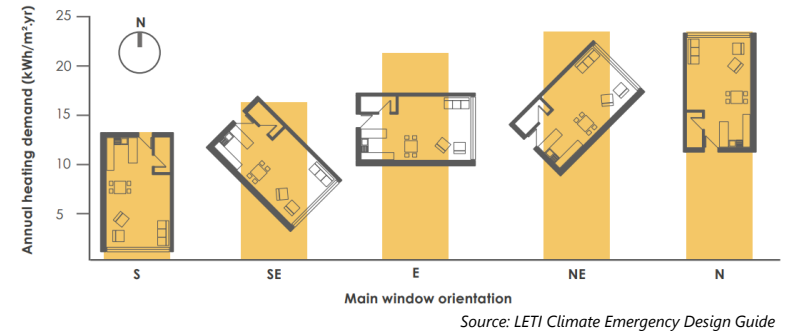

Window to wall Ratio

To achieve a balance between capturing the useful winter solar gains, and preventing summer overheating risk, it is important that the window to wall ratios are considered. The window to wall ratio is measured by dividing the total glazing area by the total external wall area. The below gives guidance on appropriate window to wall ratios for different orientations, as well as guidance on solar shading for the UK climate.

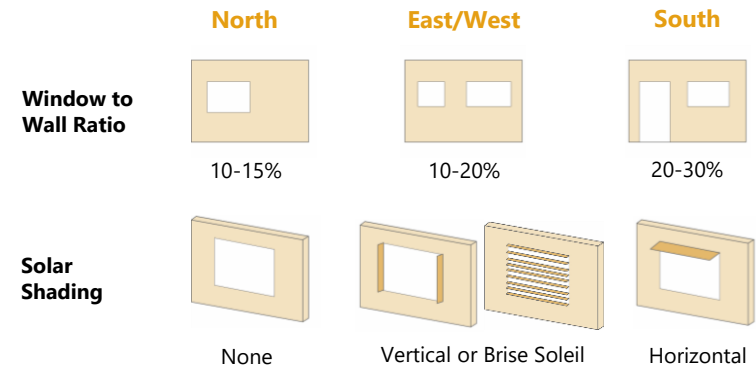

General guidance – thermal bridging

What is a thermal bridge?

Thermal bridges are junctions through which heat transfers from the interior to exterior. They typically occur on structural junctions, such as studs, beams or other structural components that penetrate the insulation layer. It is important to mitigate thermal bridges to reduce heat losses and lower the condensation risk.

The impact of a thermal bridge, depends on the junction's total length and its heat transfer rate. The product of these two gives us the psi-value of each thermal bridge (W/mK). Therefore, the longer the length of the thermal bridge or the higher the heat transfer through the junction, means it will have a greater impact on the heat losses of the building. The most impactful thermal bridges are commonly the window and door, balcony to wall, and parapet junctions.

Step 1 and 2 - reduce the number and impact of thermal bridges

It is important that thermal bridges are reduced through the implementation of key design strategies such as:

- optimization of the building's form factor to reduce the number and length of thermal bridges;
- optimization of the wall-to-glazing ratio to reduce length of window to wall junctions;
- design of access walkways or balconies to be structurally supported and tied back to the building, rather than cantilevered to reduce the impact and cost of thermal connectors;
- ensure insulation continuity to eliminate gaps and potential heat losses around the building

The remaining thermal bridges are addressed through careful detail design that includes the specification of the right thermal products such as:

- lower thermal conductivity brick ties for traditional construction;
- thermal blocks for internal wall to ground floor junctions; and
- structural thermal breaks for balconies to internal floor/ external wall junctions.

Step 3 - calculating psi-values

Meeting building regulations Part L and achieving net zero requires the calculation and reporting of thermal bridges. 2d or 3d Psi-value calculations will need to be carried out for each thermal bridge (bearing in mind the slight differences in outputs required for PHPP and SAP).

A combined thermal bridging figure is reported from SAP called the y-value (W/m²K).

A total thermal bridge heat losses figure is reported from PHPP (kwh/m²/yr).

The y-value and heat loss figures are applicable only to the dwelling of the size, configuration and construction for which it is calculated.

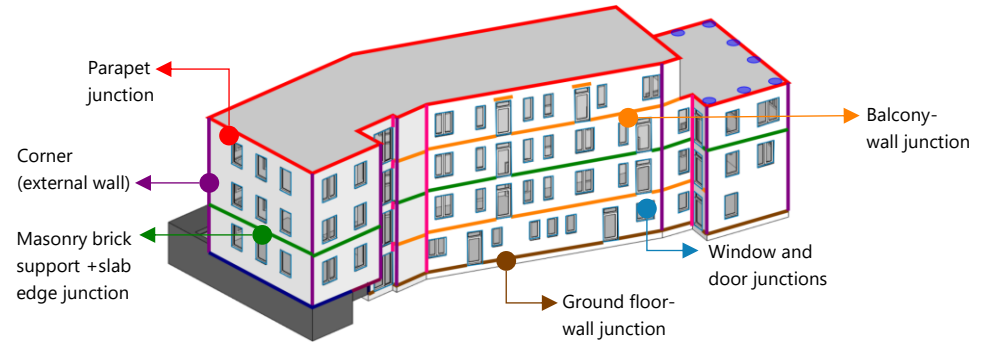

Example of the location of thermal bridge junctions. Different colours indicate the different types of thermal bridge that exist in this scheme. Typically a Psi value would be calculated for each of these junctions.

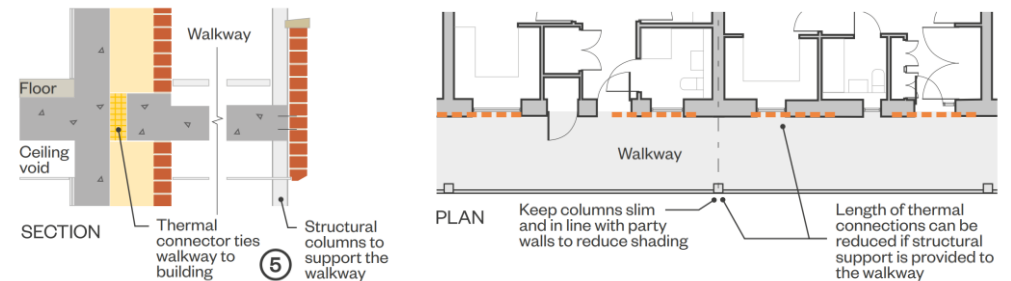
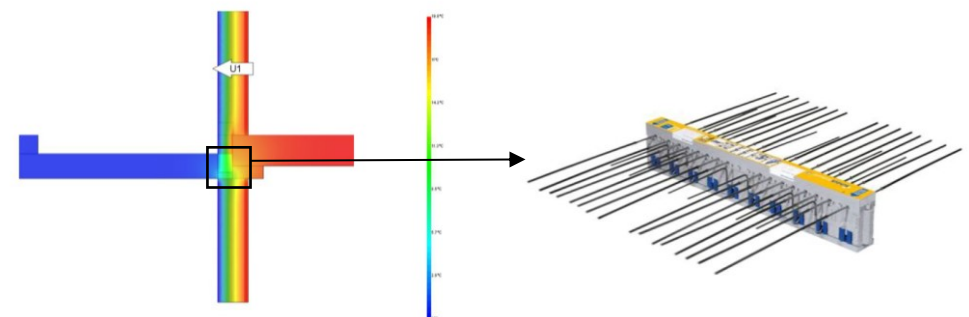

Diagram illustrating how to design out thermal bridges on access walkways. Source: Passivhaus easi-guide



Energy flow diagram produced for a balcony to internal floor/external wall junction, produced from a Psi-value calculation. Example Schock Isokorb thermal break was tested to mitigate this thermal bridge.

3.0 Net Zero Specifications

- **Semi-detached house**
- **Terrace block**
- **Bungalow**
- **Low-rise block of flats**
- **Mid-rise block of flats**
- **High-rise block of flats**

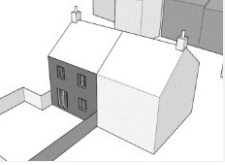

Semi-detached house

15
kWh/m²/year

Space Heating Demand

35
kWh/m²/year

Energy Use Intensity



Fossil Fuel Free



Renewable Energy Generation

Fabric options

Element	U-value (W/m ² /K)	Approx. total thickness (mm)	Build-up description	Build-up example
External walls	0.12 – 0.15	450-550	EW-01: Traditional brick and block + full or partial fill glass wool insulation	
		500-520	EW-02: Stick timber frame + cellulose insulation + brick	
		~420	EW-03: Off-site timber frame + wood fibre and hempcrete insulation + render/ timber weatherboard	
Roof	≤ 0.10	~380	R-01: Timber rafters + mineral wool insulation + tiles	
		~580	R-02: Timber I-joists + cellulose insulation + tiles	
		~510	R-03: Timber rafters + phenolic insulation + tiles	
Ground floor	0.08-0.10	~360	GF-01: Suspended beam and block floor	
		~600	GF-02: In-situ concrete slab	
Glazing	0.8		Triple glazed with a g-value of approx. 0.5	

Ventilation System

Mechanical Ventilation with Heat Recovery

MVHR units are very important for maintaining good air quality and reducing heat losses within a dwelling. It exchanges heat between the outgoing and incoming air, which reduces the heating requirements.

Moist warm air from kitchens and bathrooms (A) is extracted and discharged to the atmosphere (D), as this happens, the heat is exchanged (E) to the incoming fresh air (B), which is then supplied to the other rooms in the dwelling (C).

All dwelling ductwork shall be in PVC flat channel ducting wherever possible.

Fresh air and exhaust air inlet/outlets are required on the building façade and ducted to the MVHR unit.

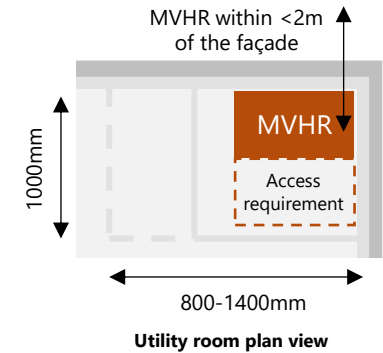
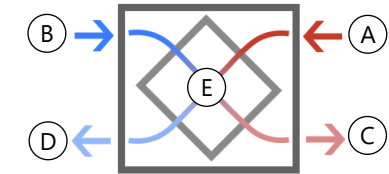

Key requirements for best practice MVHR design

Distance from external wall	<2m	
Fan efficiency (SAP and PHPP)	<0.85 W/l/s (SAP)	<0.3 Wh/m ³ (PHPP)
Heat recovery	>90%	
Thickness of duct insulation	>25mm	
Maintenance	Front access is required to the full width of the utility cupboard for replacement and maintenance.	
Ceiling void	MVHR ducts will be distributed in the ceiling. Allow a minimum of 150-250mm distribution zone	

Airtightness

To achieve a low energy home with low space heating demand high performing airtightness is required, as well as high performing fabric.

Recommended airtightness (measured at a pressure of 50 pascals)	SAP (m ³ /m ² /hr)	PHPP (ach)
Airtightness	≤0.6	≤0.6



Semi-detached house

Heating and Hot Water System Options

Option 1: Local ASHP

Heat is generated by a local air-to-water air source heat pump located externally adjacent to each dwelling. The dwelling only requires an electrical supply for the unit. A wet heating system is provided to deliver space heating and domestic hot water internally.

The unit must be located at least 1 m away from the boundary of property.

Ventilation to the space is via an MVHR that is separate to the heating system.

Space Heating Flow temperature: 45°C

Equipment:

- ASHP per dwelling
- Hot water cylinder per dwelling
- MVHR per dwelling – connected to façade locally.
- Wet radiator system and distribution within dwelling

Primary System: NA

Minimum system efficiency requirement to achieve net zero:

- Space heating and domestic hot water: 250%

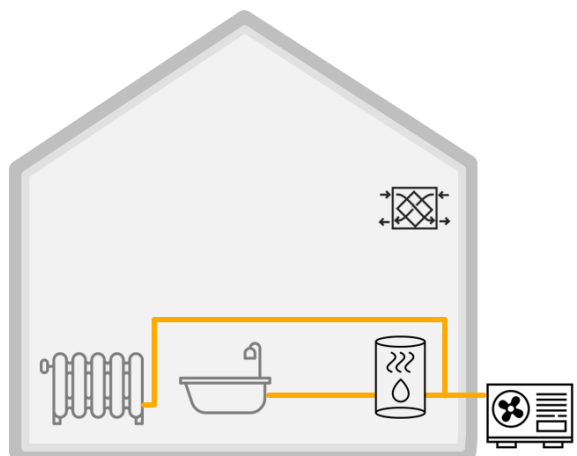

Option 2: Local exhaust ASHP

Each residential dwelling has its own exhaust air source heat pump (ExASHP) packaged system which includes an MVHR, heat pump and a hot water cylinder. The ExASHP uses the air extracted from the dwelling as the heat source for a heat pump which produces hot water and heat for the dwelling. Space heating is produced centrally and distributed, via air through the ventilation system to the living spaces. Stale air is extracted from bathrooms, kitchens and utility cupboards.

Supplementary direct electric panel radiators may also be provided for peak heat loss. This system is reliant on high fabric performance in order to maintain affordable running costs.

Space Heating Flow temperature: NA (All air system)

Equipment:

- ExASHP per apartment, which includes the hot water store – connected to façade locally.
- All air heating system ductwork and distribution within apartment

Primary System: NA

Minimum system efficiency requirement to achieve net zero:

- Space heating and domestic hot water: 320%

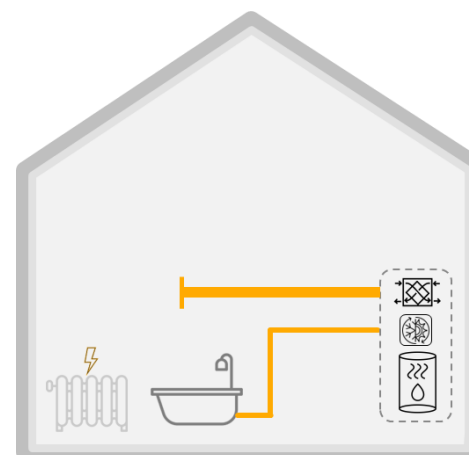

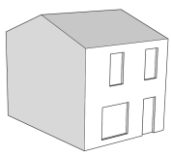

Terrace Block

15
kWh/m²/year

Space Heating Demand

35
kWh/m²/year

Energy Use Intensity



Fossil Fuel Free



Renewable Energy Generation

Fabric options

Element	U-value (W/m ² /K)	Approx. total thickness (mm)	Build-up description	Build-up example
External walls	0.12 – 0.15	450-550	EW-01: Traditional brick and block + full or partial fill glass wool insulation	
		500-520	EW-02: Stick timber frame + cellulose insulation + brick	
		~420	EW-03: Off-site timber frame + wood fibre and hempcrete insulation + render/ timber weatherboard	
Roof	≤ 0.10	~380	R-01: Timber rafters + mineral wool insulation + tiles	
		~580	R-02: Timber I-joists + cellulose insulation + tiles	
		~510	R-03: Timber rafters + phenolic insulation + tiles	
Ground floor	0.08-0.10	~360	GF-01: Suspended beam and block floor	
		~600	GF-02: In-situ concrete slab	
Glazing	0.8	Triple glazed with a g-value of approx. 0.5		

Ventilation System

Mechanical Ventilation with Heat Recovery

MVHR units are very important for maintaining good air quality and reducing heat losses within a dwelling. It exchanges heat between the outgoing and incoming air, which reduces the heating requirements.

Moist warm air from kitchens and bathrooms (A) is extracted and discharged to the atmosphere (D), as this happens, the heat is exchanged (E) to the incoming fresh air (B), which is then supplied to the other rooms in the dwelling (C).

All dwelling ductwork shall be in PVC flat channel ducting wherever possible.

Fresh air and exhaust air inlet/outlets are required on the building façade and ducted to the MVHR unit.

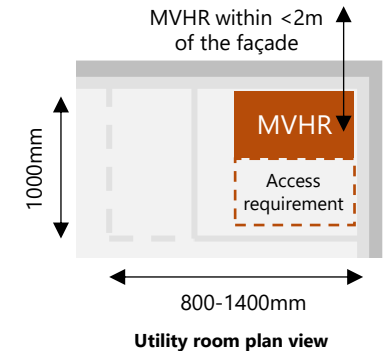
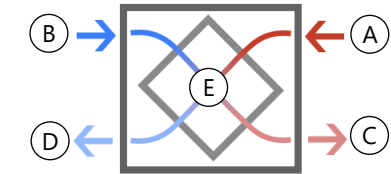

Key requirements for best practice MVHR design

Distance from external wall	<2m	
Fan efficiency (SAP and PHPP)	<0.85 W/l/s (SAP)	<0.3 Wh/m ³ (PHPP)
Heat recovery	>90%	
Thickness of duct insulation	>25mm	
Maintenance	Front access is required to the full width of the utility cupboard for replacement and maintenance.	
Ceiling void	MVHR ducts will be distributed in the ceiling. Allow a minimum of 150-250mm distribution zone	

Airtightness

To achieve a low energy home with low space heating demand high performing airtightness is required, as well as high performing fabric.

Recommended airtightness (measured at a pressure of 50 pascals)	SAP (m ³ /m ² /hr)	PHPP (ach)
Airtightness	≤0.65	≤0.6

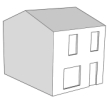

Terrace Block

Heating and Hot Water System Options

Option 1: Local ASHP

Heat is generated by a local air-to-water air source heat pump located externally adjacent to each dwelling. The dwelling only requires an electrical supply for the unit. A wet heating system is provided to deliver space heating and domestic hot water internally.

The unit must be located at least 1 m away from the boundary of property.

Ventilation to the space is via an MVHR that is separate to the heating system.

Space Heating Flow temperature: 45°C

Equipment:

- ASHP per dwelling
- Hot water cylinder per dwelling
- MVHR per dwelling – connected to façade locally.
- Wet radiator system and distribution within dwelling

Primary System: NA

Minimum system efficiency requirement to achieve net zero:

- Space heating and domestic hot water: 250%

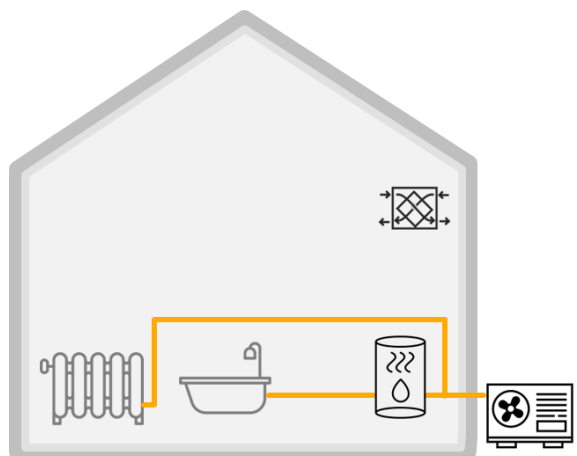

Option 2: Local exhaust ASHP

Each residential dwelling has its own exhaust air source heat pump (ExASHP) packaged system which includes an MVHR, heat pump and a hot water cylinder. The ExASHP uses the air extracted from the dwelling as the heat source for a heat pump which produces hot water and heat for the dwelling. Space heating is produced centrally and distributed, via air through the ventilation system to the living spaces. Stale air is extracted from bathrooms, kitchens and utility cupboards.

Supplementary direct electric panel radiators may also be provided for peak heat loss. This system is reliant on high fabric performance in order to maintain affordable running costs.

Space Heating Flow temperature: NA (All air system)

Equipment:

- ExASHP per apartment, which includes the hot water store – connected to façade locally.
- All air heating system ductwork and distribution within apartment

Primary System: NA

Minimum system efficiency requirement to achieve net zero:

- Space heating and domestic hot water: 320%

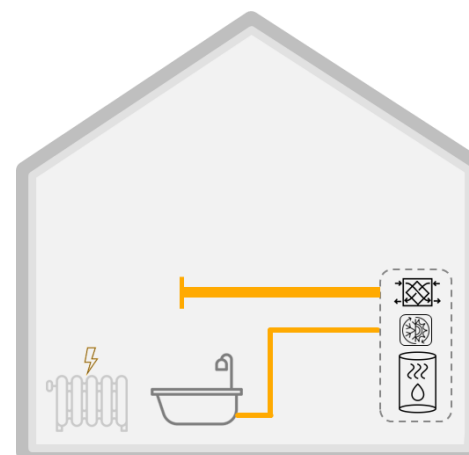



Bungalow

20
kWh/m²/year

Space Heating Demand

35
kWh/m²/year

Energy Use Intensity



Fossil Fuel Free



Renewable Energy Generation

Fabric options

Element	U-value (W/m ² /K)	Approx. total thickness (mm)	Build-up description	Build-up example
External walls	0.09 – 0.12	~450	EW-01: Traditional brick and block + glass wool insulation	
		~500	EW-02: Stick timber frame + cellulose insulation + brick	
		~420	EW-03: Off-site timber frame + wood fibre and hempcrete insulation + render	
		~490	EW-04: Traditional brick and block + XPS insulation	
Roof	≤ 0.10	~380	R-01: Timber rafters + mineral wool insulation + tiles	
		~580	R-02: Timber I-joists + cellulose insulation + tiles	
		~510	R-03: Timber rafters + phenolic insulation + tiles	
Ground floor	0.08-0.10	~360	GF-01: Suspended beam and block floor	
		~600	GF-02: In-situ concrete slab	
Glazing	0.8	Triple glazed with a g-value of approx. 0.5		

Ventilation System – Mechanical Ventilation with Heat Recovery

MVHR units are very important for maintaining good air quality and reducing heat losses within a dwelling. It exchanges heat between the outgoing and incoming air, which reduces the heating requirements.

Moist warm air from kitchens and bathrooms (A) is extracted and discharged to the atmosphere (D), as this happens, the heat is exchanged (E) to the incoming fresh air (B), which is then supplied to the other rooms in the dwelling (C).

All dwelling ductwork shall be in PVC flat channel ducting wherever possible.

Fresh air and exhaust air inlet/outlets are required on the building façade and ducted to the MVHR unit.

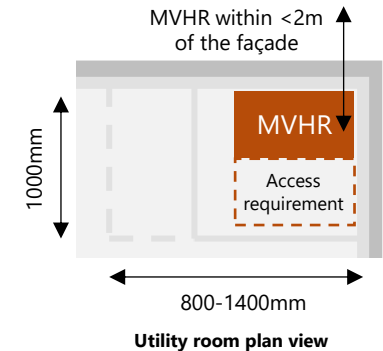
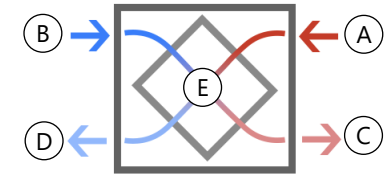

Key requirements for best practice MVHR design

Distance from external wall	<2m	
Fan efficiency (SAP and PHPP)	<0.85 W/l/s (SAP)	<0.3 Wh/m ³ (PHPP)
Heat recovery	>90%	
Thickness of duct insulation	>25mm	
Maintenance	Front access is required to the full width of the utility cupboard for replacement and maintenance.	
Ceiling void	MVHR ducts will be distributed in the ceiling. Allow a minimum of 150-250mm distribution zone	

Airtightness

To achieve a low energy home with low space heating demand high performing airtightness is required, as well as high performing fabric.

Recommended airtightness (measured at a pressure of 50 pascals)	SAP (m ³ /m ² /hr)	PHPP (ach)
Airtightness	≤0.4	≤0.6

Heating and Hot Water System Options

Option 1: Local ASHP

Heat is generated by a local air-to-water air source heat pump located externally adjacent to each dwelling. The dwelling only requires an electrical supply for the unit. A wet heating system is provided to deliver space heating and domestic hot water internally.

The unit must be located at least 1 m away from the boundary of property.

Ventilation to the space is via an MVHR that is separate to the heating system.

Space Heating Flow temperature: 45°C

Equipment:

- ASHP per dwelling
- Hot water cylinder per dwelling
- MVHR per dwelling – connected to façade locally.
- Wet radiator system and distribution within dwelling

Primary System: NA

Minimum system efficiency requirement to achieve net zero:

- Space heating and domestic hot water: 250%

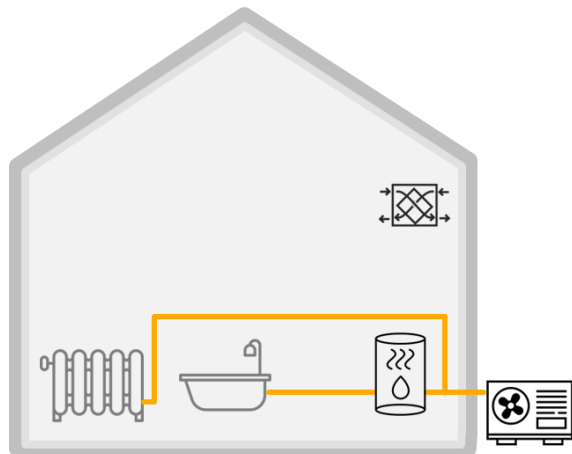

Option 2: Local exhaust ASHP

Each residential dwelling has its own exhaust air source heat pump (ExASHP) packaged system which includes an MVHR, heat pump and a hot water cylinder. The ExASHP uses the air extracted from the dwelling as the heat source for a heat pump which produces hot water and heat for the dwelling. Space heating is produced centrally and distributed, via air through the ventilation system to the living spaces. Stale air is extracted from bathrooms, kitchens and utility cupboards.

Supplementary direct electric panel radiators may also be provided for peak heat loss. This system is reliant on high fabric performance in order to maintain affordable running costs.

Space Heating Flow temperature: NA (All air system)

Equipment:

- ExASHP per apartment, which includes the hot water store – connected to façade locally.
- All air heating system ductwork and distribution within apartment

Primary System: NA

Minimum system efficiency requirement to achieve net zero:

- Space heating and domestic hot water: 320%

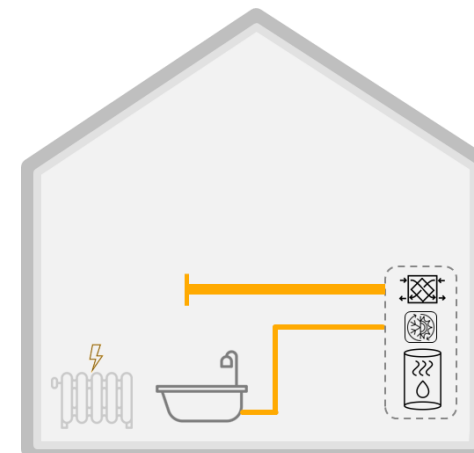

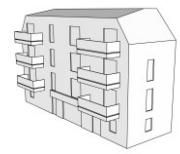

Low-rise block of flats – up to 11m*

15
kWh/m²/year

Space Heating Demand

35
kWh/m²/year

Energy Use Intensity



Fossil Fuel Free



Renewable Energy Generation

Fabric options

Element	U-value (W/m ² /K)	Approx. total thickness (mm)	Build-up description	Build-up example
External walls	0.12 – 0.15	450-550	EW-01: Traditional brick and block + full or partial fill glass wool insulation	
		500-520	EW-02: Stick timber frame + cellulose insulation + brick	
		~420	EW-03: Off-site timber frame + wood fibre and hempcrete insulation + render/ timber weatherboard	
Roof	≤ 0.10	~380	R-01: Timber rafters + mineral wool insulation + tiles	
		~580	R-02: Timber I-joists + cellulose insulation + tiles	
		~510	R-03: Timber rafters + phenolic insulation + tiles	
Ground floor	0.08-0.10	~360	GF-01: Suspended beam and block floor	
		~600	GF-02: In-situ concrete slab	
Glazing	0.8	Triple glazed with a g-value of approx. 0.5		

Ventilation System – Mechanical Ventilation with Heat Recovery

MVHR units are very important for maintaining good air quality and reducing heat losses within a dwelling. It exchanges heat between the outgoing and incoming air, which reduces the heating requirements.

Moist warm air from kitchens and bathrooms (A) is extracted and discharged to the atmosphere (D), as this happens, the heat is exchanged (E) to the incoming fresh air (B), which is then supplied to the other rooms in the dwelling (C).

All dwelling ductwork shall be in PVC flat channel ducting wherever possible. Ductwork running through the apartment protected corridors shall have intumescent fire dampers as the duct passes through the fire walls as designated by the fire strategy plans.

Fresh air and exhaust air inlet/outlets are required on the building façade and ducted to the MVHR unit.

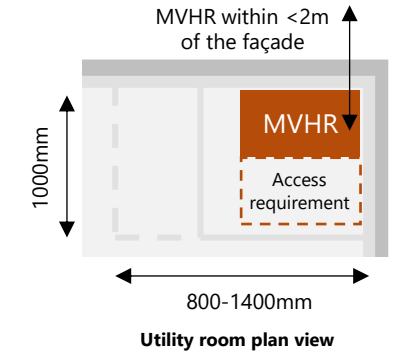
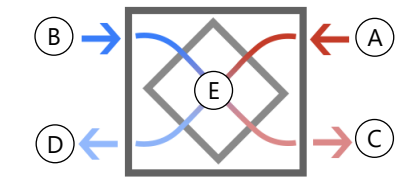

Key requirements for best practice MVHR design

Distance from external wall	<2m	
Fan efficiency (SAP and PHPP)	<0.85 W/l/s (SAP)	<0.3 Wh/m ³ (PHPP)
Heat recovery	>90%	
Thickness of duct insulation	>25mm	
Maintenance	Front access is required to the full width of the utility cupboard for replacement and maintenance.	
Ceiling void	MVHR ducts will be distributed in the ceiling. Allow a minimum of 150-250mm distribution zone	

Airtightness

To achieve a low energy home with low space heating demand high performing airtightness is required, as well as high performing fabric.

Recommended airtightness (measured at a pressure of 50 pascals)	SAP (m ³ /m ² /hr)	PHPP (ach)
Airtightness	≤0.75	≤0.6

* Under building regulations Part B (2010 with 2020 amendments), buildings with a top occupied storey of 18m or more above ground should have non-combustible materials in the construction of its external walls. For buildings between 11m-18m in height, the external surface of wall and any insulation product used in the external wall should be Class A2-s1, d0 or better (non-combustible). For buildings below 11m in height, Class C-s3, d2 materials can be used.



Low-rise block of flats

Heating and Hot Water System Options

Option 1: Local ASHP

Heat is generated by a local air-to-water air source heat pump located externally adjacent to each dwelling. The dwelling only requires an electrical supply for the unit. A wet heating system is provided to deliver space heating and domestic hot water internally.

For apartments, ASHPs can be located on balconies, however attention must be paid to noise, and the unit may be needed to be 1m away from boundary of the demise.

Ventilation to the space is via an MVHR that is separate to the heating system.

Space Heating Flow temperature: 45°C

Equipment:

- ASHP per dwelling
- Hot water cylinder per dwelling
- MVHR per dwelling – connected to façade locally.
- Wet radiator system and distribution within dwelling

Primary System: NA

Minimum system efficiency requirement to achieve net zero:

- Space heating and domestic hot water: 250%

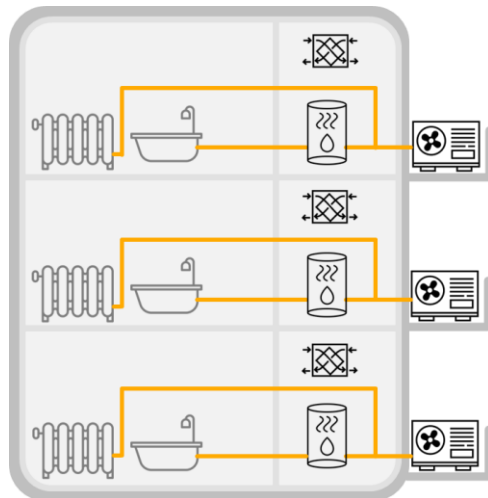

Option 2: Local exhaust ASHP

Each residential dwelling has its own exhaust air source heat pump (ExASHP) packaged system which includes an MVHR, heat pump and a hot water cylinder. The ExASHP uses the air extracted from the dwelling as the heat source for a heat pump which produces hot water and heat for the dwelling. Space heating is produced centrally and distributed, via air through the ventilation system to the living spaces. Stale air is extracted from bathrooms, kitchens and utility cupboards.

Supplementary direct electric panel radiators can also be provided for peak heat loss. This system is reliant on high fabric performance in order to maintain affordable running costs.

Space Heating Flow temperature: NA (All air system)

Equipment:

- ExASHP per apartment, which includes the hot water store – connected to façade locally.
- All air heating system ductwork and distribution within apartment

Primary System: NA

Minimum system efficiency requirement to achieve net zero:

- Space heating and domestic hot water: 320%

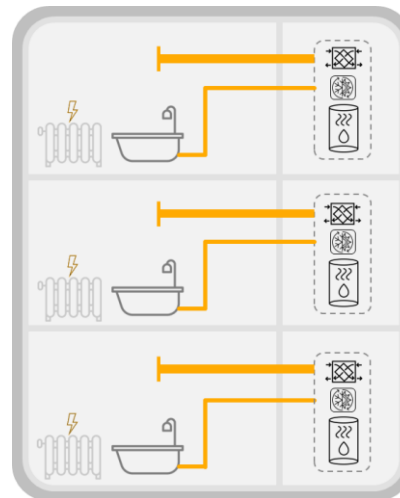

Option 3: Direct Electric Heating with local DHW Heat Pump

Space heating is generated by direct electric panel radiators. Hot water is generated in a combined heat pump and hot water storage cylinder. The heat pump requires ducted air connections to the façade and an electrical supply. This system relies on the high-performance fabric to ensure the operational energy for heating is affordable.

Ventilation to the space is via an MVHR that is separate to the heating system.

Detailing of the supply and exhaust connections to the heat pump is key to prevent heat loss/infiltration and coordination of two extra ducts to the façade is necessary.

Space Heating Flow temperature: NA (direct electric radiators)

Equipment:

- Heat pump hot water cylinder per dwelling – connected to façade locally.
- MVHR per apartment – connected to façade locally
- Wet radiator system and distribution within apartment

Primary System: NA

Minimum system efficiency requirement to achieve net zero:

- Space heating - Direct Electric Panels: 100%
- Domestic Hot Water - Heat pump: 330%

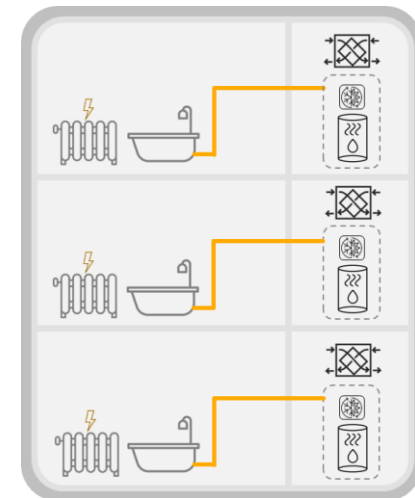

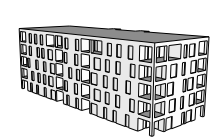

Mid-rise block of flats – greater than 18m*

15
kWh/m²/year

Space Heating Demand

35
kWh/m²/year

Energy Use Intensity



Fossil Fuel Free



Renewable Energy Generation

Fabric options

Element	U-value (W/m ² /K)	Approx. total thickness (mm)	Build-up description	Build-up example
External Walls	0.12-0.18	550-600	EW-05: Concrete frame + light gauge steel infill + brick/render/rainscreen	
Roof	0.09	~700	R-04: Inverted roof, concrete frame + waterproofing + XPS insulation + ballast	
Ground Floor	0.08-0.10	~360	GF-01: Suspended beam and block floor	
		~600	GF-02: In-situ concrete slab	
Glazing	0.8		Triple glazed with a g-value of approx. 0.5	

Ventilation System – Mechanical Ventilation with Heat Recovery

MVHR units are very important for maintaining good air quality and reducing heat losses within a dwelling. It exchanges heat between the outgoing and incoming air, which reduces the heating requirements.

Moist warm air from kitchens and bathrooms (A) is extracted and discharged to the atmosphere (D), as this happens, the heat is exchanged (E) to the incoming fresh air (B), which is then supplied to the other rooms in the dwelling (C).

All dwelling ductwork shall be in PVC flat channel ducting wherever possible. Ductwork running through the apartment protected corridors shall have intumescent fire dampers as the duct passes through the fire walls as designated by the fire strategy plans.

Fresh air and exhaust air inlet/outlets are required on the building façade and ducted to the MVHR unit.

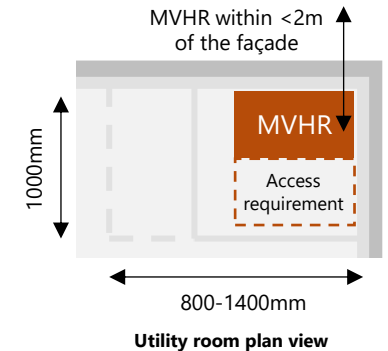
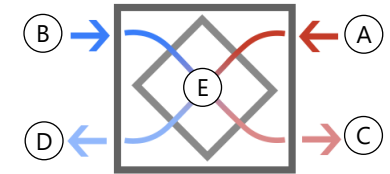

Key requirements for best practice MVHR design

Distance from external wall	<2m	
Fan efficiency (SAP and PHPP)	<0.85 W/l/s (SAP)	<0.3 Wh/m ³ (PHPP)
Heat recovery	>90%	
Thickness of duct insulation	>25mm	
Maintenance	Front access is required to the full width of the utility cupboard for replacement and maintenance.	
Ceiling void	MVHR ducts will be distributed in the ceiling. Allow a minimum of 150-250mm distribution zone	

Airtightness

To achieve a low energy home with low space heating demand high performing airtightness is required, as well as high performing fabric.

Recommended airtightness (measured at a pressure of 50 pascals)	SAP (m ³ /m ² /hr)	PHPP (ach)
Airtightness	≤1	≤0.6

* Under building regulations Part B (2010 with 2020 amendments), buildings with a top occupied storey of 18m or more above ground should have non-combustible materials in the construction of its external walls. For buildings between 11m-18m in height, the external surface of wall and any insulation product used in the external wall should be Class A2-s1, d0 or better (non-combustible). For buildings below 11m in height, Class C-s3, d2 materials can be used.



Mid-rise block of flats

Heating and Hot Water System Options

Option 1: Passive Ambient Loop

Each apartment has a small shoebox water source heat pump that uses a communal ambient loop as a heat source. The communal ambient loop extracts heat from the ground. Each apartment requires a hot water store and heat is provided through a wet heating system with radiators.

Heating flow temperature: The temperature of the ambient loop will vary depending on season, fluctuating between 8°C and 20°C. Inside the dwellings for optimum heat pump efficiency the heating system will function on 35°C flow / 30°C return, however the system will be capable of producing a flow temperature of 65°C when hot water is being generated.

Equipment:

- Shoebox heat pump per apartment
- MVHR per apartment – connected to façade locally.
- Wet radiator system and distribution within apartment

Primary System:

- Passive borehole system

Minimum system efficiency requirement to achieve net zero:

- Space heating and domestic hot water: 300%

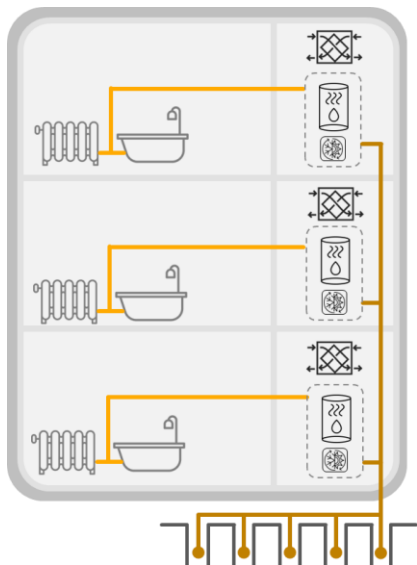

Option 2: Local exhaust ASHP

Each residential dwelling has its own exhaust air source heat pump (ExASHP) packaged system which includes an MVHR, heat pump and a hot water cylinder. The ExASHP uses the air extracted from the dwelling as the heat source for a heat pump which produces hot water and heat for the dwelling. Space heating is produced centrally and distributed, via air through the ventilation system to the living spaces. Stale air is extracted from bathrooms, kitchens and utility cupboards.

Supplementary direct electric panel radiators can also be provided for peak heat loss. This system is reliant on high fabric performance in order to maintain affordable running costs.

Space Heating Flow temperature: NA (All air system)

Equipment:

- ExASHP per apartment, which includes the hot water store – connected to façade locally.
- All air heating system ductwork and distribution within apartment

Primary System: NA

Minimum system efficiency requirement to achieve net zero:

- Space heating and domestic hot water: 320%

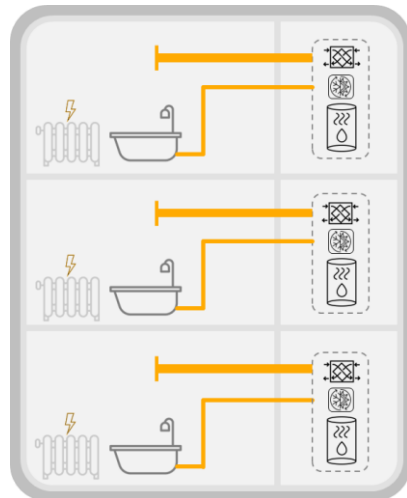

Option 3: Direct Electric Heating with local DHW Heat Pump

Space heating is generated by direct electric panel radiators. Hot water is generated in a combined heat pump and hot water storage cylinder. The heat pump requires ducted air connections to the façade and an electrical supply. This system relies on the high-performance fabric to ensure the operational energy for heating is affordable.

Ventilation to the space is via an MVHR that is separate to the heating system.

Detailing of the supply and exhaust connections to the heat pump is key to prevent heat loss/infiltration and coordination of two extra ducts to the façade is necessary.

Space Heating Flow temperature: NA (direct electric radiators)

Equipment:

- Heat pump hot water cylinder per dwelling – connected to façade locally.
- MVHR per apartment – connected to façade locally
- Wet radiator system and distribution within apartment

Primary System: NA

Minimum system efficiency requirement to achieve net zero:

- Space heating - Direct Electric Panels: 100%
- Domestic Hot Water - Heat pump: 330%

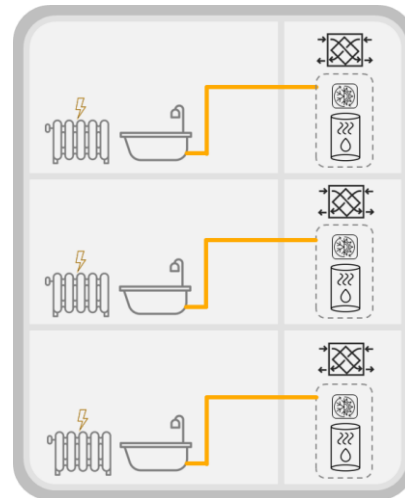

Option 4: Communal ASHP

Heat is generated by a communal air-to-water air source heat pumps. A heat Interface Unit (HIU) is required per apartment, within this unit one plate distributes heat to the space heating system, and a second plate generates instantaneous hot water. Heat is provided through a wet heating system with radiators.

Heating Flow temperature: flow and return temperature 60°C / 40°C

Equipment:

- HIU per apartment
- MVHR per apartment – connected to façade locally.
- Wet radiator system and distribution within apartment

Primary System:

- Centralised high temperature ASHP
- Communal buffer vessels.

Minimum system efficiency requirement to achieve net zero:

- Space heating and domestic hot water: 250%

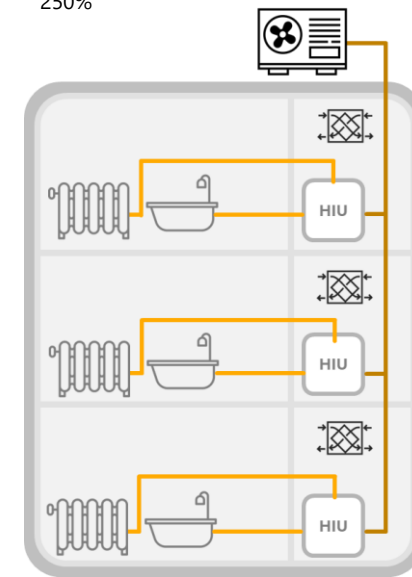



High-rise block of flats – greater than 18m*

15
kWh/m²/year

Space Heating Demand

35
kWh/m²/year

Energy Use Intensity



Fossil Fuel Free



Renewable Energy Generation

Fabric options

Element	U-value (W/m ² /K)	Approx. total thickness (mm)	Build-up description	Build-up example
External Walls	0.12-0.18	550-600	EW-05: Concrete frame + light gauge steel infill + brick/render/rainscreen	
Roof	0.09	~700	R-04: Inverted roof, concrete frame + waterproofing + XPS insulation + ballast	
Ground Floor	0.08-0.10	~360	GF-01: Suspended beam and block floor	
		~600	GF-02: In-situ concrete slab	
Glazing	0.8	Triple glazed with a g-value of approx. 0.5		

Ventilation System – Mechanical Ventilation with Heat Recovery

MVHR units are very important for maintaining good air quality and reducing heat losses within a dwelling. It exchanges heat between the outgoing and incoming air, which reduces the heating requirements.

Moist warm air from kitchens and bathrooms (A) is extracted and discharged to the atmosphere (D), as this happens, the heat is exchanged (E) to the incoming fresh air (B), which is then supplied to the other rooms in the dwelling (C).

All dwelling ductwork shall be in PVC flat channel ducting wherever possible. Ductwork running through the apartment protected corridors shall have intumescent fire dampers as the duct passes through the fire walls as designated by the fire strategy plans.

Fresh air and exhaust air inlet/outlets are required on the building façade and ducted to the MVHR unit.

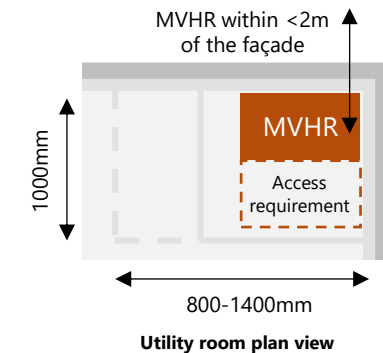
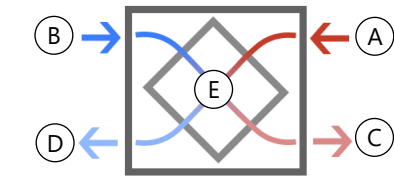

Key requirements for best practice MVHR design

Distance from external wall	<2m	
Fan efficiency (SAP and PHPP)	<0.85 W/l/s (SAP)	<0.3 Wh/m ³ (PHPP)
Heat recovery	>90%	
Thickness of duct insulation	>25mm	
Maintenance	Front access is required to the full width of the utility cupboard for replacement and maintenance.	
Ceiling void	MVHR ducts will be distributed in the ceiling. Allow a minimum of 150-250mm distribution zone	

Airtightness

To achieve a low energy home with low space heating demand high performing airtightness is required, as well as high performing fabric.

Recommended airtightness (measured at a pressure of 50 pascals)	SAP (m ³ /m ² /hr)	PHPP (ach)
Airtightness	≤1	≤0.6

* Under building regulations Part B (2010 with 2020 amendments), buildings with a top occupied storey of 18m or more above ground should have non-combustible materials in the construction of its external walls. For buildings between 11m-18m in height, the external surface of wall and any insulation product used in the external wall should be Class A2-s1, d0 or better (non-combustible). For buildings below 11m in height, Class C-s3, d2 materials can be used.



High-rise block of flats

Heating and Hot Water System Options

Option 1: Passive Ambient Loop

Each apartment has a small shoebox water source heat pump that uses a communal ambient loop as a heat source. The communal ambient loop extracts heat from the ground. Each apartment requires a hot water store and heat is provided through a wet heating system with radiators.

Heating flow temperature: The temperature of the ambient loop will vary depending on season, fluctuating between 8°C and 20°C. Inside the dwellings for optimum heat pump efficiency the heating system will function on 35°C flow / 30°C return, however the system will be capable of producing a flow temperature of 65°C when hot water is being generated.

Equipment:

- Shoebox heat pump per apartment
- MVHR per apartment – connected to façade locally.
- Wet radiator system and distribution within apartment

Primary System:

- Passive borehole system

Minimum system efficiency requirement to achieve net zero:

- Space heating and domestic hot water: 300%

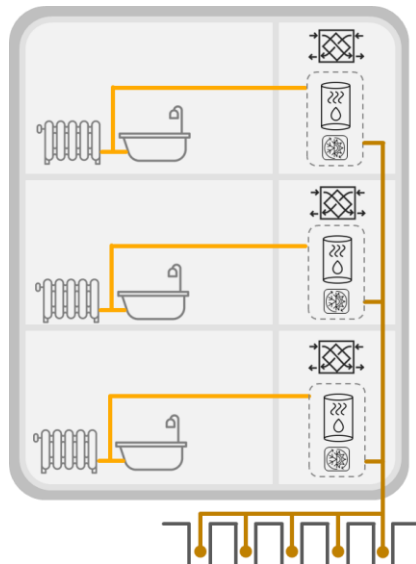

Option 2: Local exhaust ASHP

Each residential dwelling has its own exhaust air source heat pump (ExASHP) packaged system which includes an MVHR, heat pump and a hot water cylinder. The ExASHP uses the air extracted from the dwelling as the heat source for a heat pump which produces hot water and heat for the dwelling. Space heating is produced centrally and distributed, via air through the ventilation system to the living spaces. Stale air is extracted from bathrooms, kitchens and utility cupboards.

Supplementary direct electric panel radiators can also be provided for peak heat loss. This system is reliant on high fabric performance in order to maintain affordable running costs.

Space Heating Flow temperature: NA (All air system)

Equipment:

- ExASHP per apartment, which includes the hot water store – connected to façade locally.
- All air heating system ductwork and distribution within apartment

Primary System: NA

Minimum system efficiency requirement to achieve net zero:

- Space heating and domestic hot water: 320%

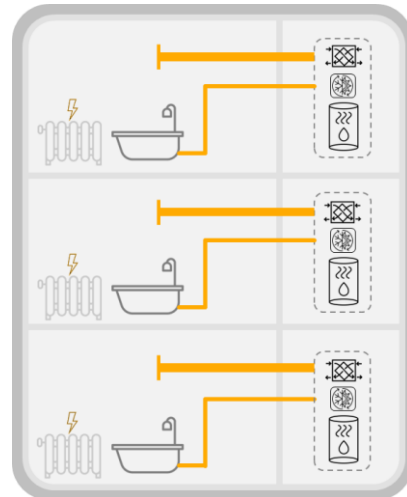

Option 3: Direct Electric Heating with local DHW Heat Pump

Space heating is generated by direct electric panel radiators. Hot water is generated in a combined heat pump and hot water storage cylinder. The heat pump requires ducted air connections to the façade and an electrical supply. This system relies on the high-performance fabric to ensure the operational energy for heating is affordable.

Ventilation to the space is via an MVHR that is separate to the heating system.

Detailing of the supply and exhaust connections to the heat pump is key to prevent heat loss/infiltration and coordination of two extra ducts to the façade is necessary.

Space Heating Flow temperature: NA (direct electric radiators)

Equipment:

- Heat pump hot water cylinder per dwelling – connected to façade locally.
- MVHR per apartment – connected to façade locally
- Wet radiator system and distribution within apartment

Primary System: NA

Minimum system efficiency requirement to achieve net zero:

- Space heating - Direct Electric Panels: 100%
- Domestic Hot Water - Heat pump: 330%

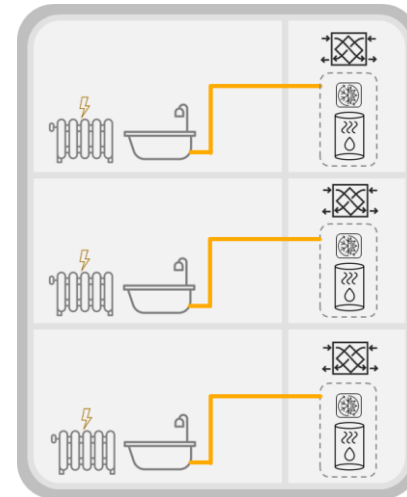

Option 4: Communal ASHP

Heat is generated by a communal air-to-water air source heat pumps. A heat Interface Unit (HIU) is required per apartment, within this unit one plate distributes heat to the space heating system, and a second plate generates instantaneous hot water. Heat is provided through a wet heating system with radiators.

Heating Flow temperature: flow and return temperature 60°C / 40°C

Equipment:

- HIU per apartment
- MVHR per apartment – connected to façade locally.
- Wet radiator system and distribution within apartment

Primary System:

- Centralised high temperature ASHP
- Communal buffer vessels.

Minimum system efficiency requirement to achieve net zero:

- Space heating and domestic hot water: 250%

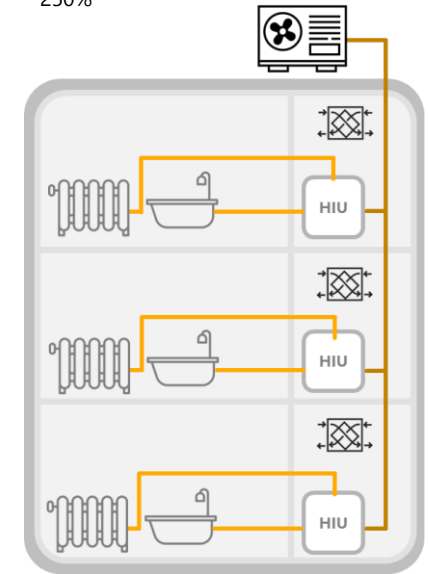

Glossary



Air source heat pump (ASHP)

An air source heat pump (sometimes referred to as an air-to-water heat pump) transfers heat from the outside air to water. This in turn heats rooms in your home via radiators or underfloor heating. It can also heat water stored in a hot water cylinder for your hot taps, showers, and baths. (Source: [Energy Saving Trust](#))



Heat interface unit (HIU)

A heat interface unit (HIU) is a box that looks like a boiler. It transfers the heat from the community heating network into the dwelling's central heating system. It makes heat available instantly, whenever its required. (Source: [Energetik](#))



Mechanical ventilation with heat recovery (MVHR)

MVHR is a whole house ventilation system that both supplies and extracts air throughout a property. This is used to reduce the heating and cooling demands of buildings. A heat recovery ventilation system works by extracting moist and stale air from wet rooms in your home, it recovers the usually lost heat from the extracted air. It also supplies clean, filtered fresh air that is heated from the recovered warmth of the extracted heat. (Source: [Envirovent](#))



Hot water cylinder

A hot water cylinder is a well-insulated tank which stores water after it's been heated. Water is heated through your boiler or heat pump system and is then stored, at temperature, ready for you to use whenever it's needed. (Source: [Vaillant](#))



Hot water Cylinder with electric immersion heater

The immersion heater sits inside a hot water cylinder and is powered by a strong electric current. It runs off the mains electric and the electric resistance heater heats the water inside the tank until it reaches the designated temperature. (Source: [Clever Energy Boilers](#))



Exhaust air source heat pump (ExASHP)

An exhaust air heat pump transfers heat from a ventilation system to warm air that heats your home. It can also be used to heat water stored in a hot water cylinder for your hot taps, showers, and baths. An exhaust air heat pump boosts the heat that the mechanical ventilation heat recovery (MVHR) unit extracts from the warm, stale air. This means that as well as saving energy, the ducting system can be used to heat the building using warm air. This removes the need to install a 'wet' central heating system using radiators or underfloor heating. (Source: [Kensa Contracting](#))



Heat pump hot water cylinder

An air-to water air source heat pumps which generate hot water for domestic use. (Source: [Modern Heat](#))



Shoebbox heat pump for passive ambient loop system

The shoebox heat pump is a small ground source heat pump specifically designed to provide both space heating and domestic hot water. The individual Shoebox heat pump inside a property is connected to a communal ground loop array system – which provides an ultra-low carbon and low-cost heating solution. (Source: [Modern Heat](#))



Wet radiators

A wet radiator is one that uses hot water for heat. Water is heated using a heat pump and then circulated via a pump to radiators where the process of convection warms the air around the radiator. (Source: [Mr Central Heating](#))



Direct electric radiators

Direct electric radiators are direct acting heaters, using standard rate electricity to heat a space up quickly by using convection heat, or a combination of radiation and convection heat. (Source: [Dimplex](#))